



NOTE

All numerical values are in metric units [with U.S. customary units in brackets]. Dimensions are in millimeters. Unless otherwise specified, dimensions have a tolerance of $\pm 0.1\text{mm}$ and angles have a tolerance of $\pm 2^\circ$. Figures and illustrations are for identification only and are not drawn to scale.

1. INTRODUCTION

This specification covers the requirements for application of SOLARLOK 2.0 family used for an electrical power connection. This connector is available in sealed for multiple Cable gauges. The SOLARLOK 2.0 has pending on the version single or multiple Cable entry holes or PV4-S interface. The button features a line which indicates how far the cable needs to be inserted. When pressed, the buttons force the Cables into the contact. The housing design provides strain relief for the Cable.



NOTE

It is strongly recommended to locate the connector inside an enclosure if it is used outside.

When corresponding with personnel, use the terminology provided in this specification to facilitate inquiries for information. Basic terms and features of this product are provided in Figure 1.

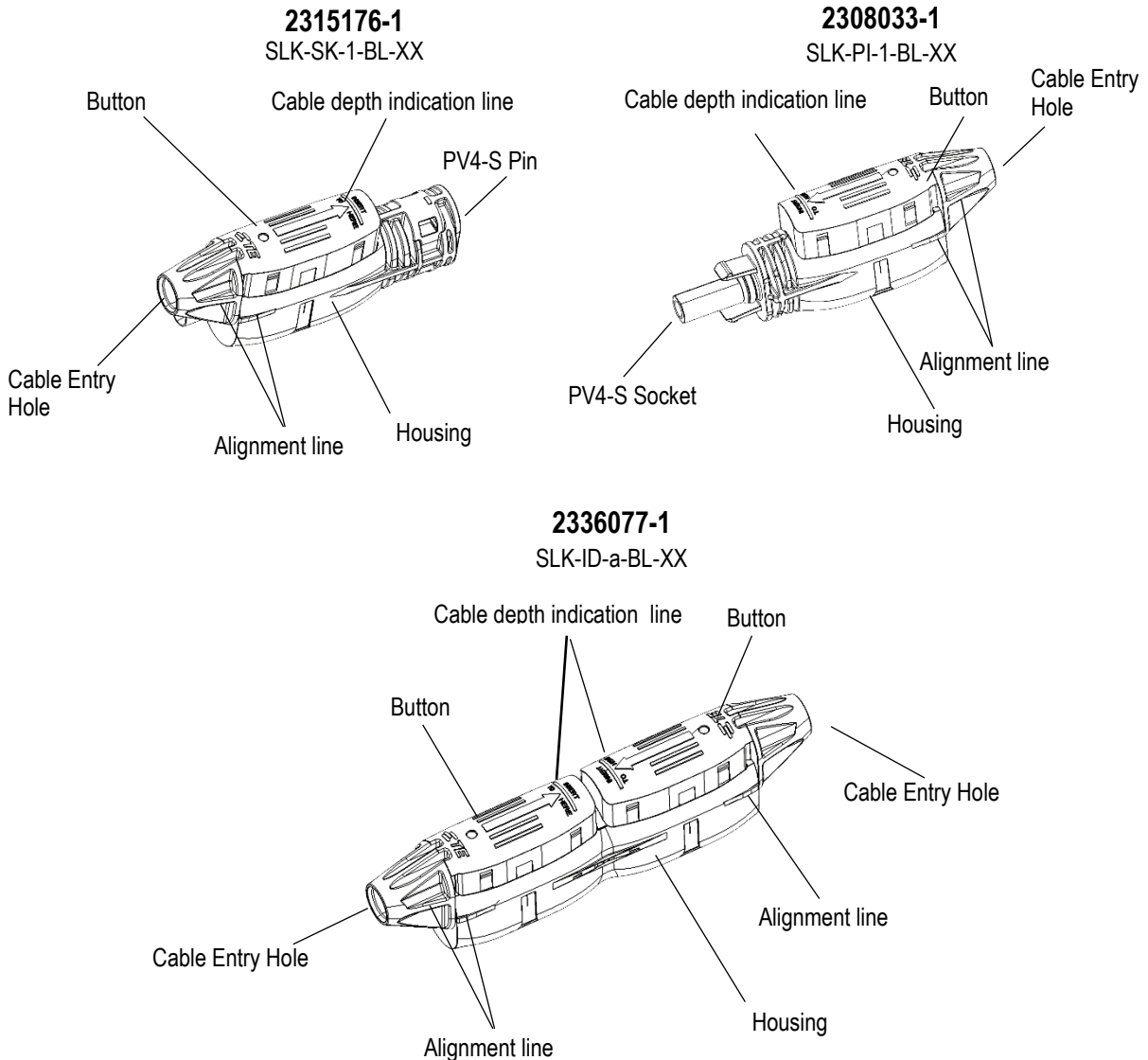

Figure 1

Part number	Name	Cable range*	Model code	Voltage	Current	Temperature
2308033-1	SOLARLOK 2.0 Socket Connector	2.5 mm ² to 6 mm ² 14 AWG to 10 AWG	SLK-SK-1-BL-XX	1500 V dc (IEC and UL) 2000 V dc (tested for IEC)	IEC: 30 A for 2.5 mm ² 35 A for 4.0 mm ² 40 A for 6.0 mm ² UL: 15 A for 14 AWG 20 A for 12 AWG 30 A for 10 AWG	-40 °C to 85 °C (ambient for IEC and UL)
2315176-1	SOLARLOK 2.0 Pin Connector	2.5 mm ² to 6 mm ² 14 AWG to 10 AWG	SLK-PI-1-BL-XX			
2336077-1	SOLARLOK 2.0 Splice	2.5 mm ² to 6 mm ² 14 AWG to 10 AWG	SLK-ID-a-BL-XX			

Figure 2

*For UL cable with an outside diameter of 5.9 mm to 7.2 mm are permissible.

*For TÜV the following cables have been approved in combination with the SOLARLOK 2.0:

- TE cable PN 2328394, 2.5 mm² (14 AWG)
- TE cable PN 2270245, 4mm² (12 AWG)
- TE cable PN 2270260, 4mm² (12 AWG)
- TE cable PN 2328400, 6mm² (10 AWG)
- TE cable PN 2270215, 4mm² (12 AWG)
- TE cable PN 2270259, 4mm² (12 AWG)
- Byson 6351D, 2.5 mm² (14 AWG)
- Byson 6352D, 4 mm² (12 AWG)
- Byson 6353D, 6 mm² (10 AWG)
- Honglin 4 mm² (12 AWG)

*additional cables with an outside diameter of 5.5 mm up to 5.9 are under certification approval.

2. REFERENCE MATERIAL

2.1. Revision Summary

Initial release of application specification

2.2. Customer Assistance

Reference Product Part Number 2308033-1, 2315176-1 & 2336077-1 and Product Code L294 are representative of SOLARLOK 2.0 family. Use of these numbers will identify the product line and help you to obtain product and tooling information when visiting www.te.com or calling the number +1-800-522-6752.

2.3. Drawings

Customer drawings for product part numbers are available from www.te.com. Information contained in the customer drawing takes priority.

2.4. Specifications

- | | |
|------------|---|
| 107-133104 | Product packaging specification |
| 108-133104 | Product Specification, provides product performance |
| 114-137077 | Application Specification PV4-S Connector |
| 501-19266 | Qualification Test Report: SOLARLOK 2.0 |
| 502-153332 | SOLARLOK 2.0 Intermateability; SOLARLOK 2.0 PV4-S to PV4-XX |

TE recommends for the general Solar installations to follow and use the norm VDE 0100-712 & 0100-520.

3. REQUIREMENTS

3.1. Storage

A. Shelf Life

The product should remain in the shipping containers until ready for use to prevent deformation to components. The product should be used on a first in, first out basis to avoid storage contamination that could adversely affect performance. According IEC68 (15-35°C, 25-75% relative humidity).

B. Chemical Exposure

Do not store product near any chemical listed below as they may cause stress corrosion cracking in the material.

Alkalies	Ammonia	Citrates	Phosphates	Citrates	Sulfur Compounds
Amines	Carbonates	Nitrites	Sulfur Nitrites		Tartrates

3.2. Cable Selection and Preparation

The connector accepts copper stranded Cable having the sizes and types given in Figure 2
Non-concentric Cable is not acceptable.



NOTE

For suitability of other Cable types, call the number at the bottom of page 1.

The cable must be clean and free of contaminates, such as dust or other substances that can compromise the insulation diameter. A cloth can be used to wipe the insulation clean, do not use any cleaning agent. The cable insulation must not be damaged or cut, it is preferable to use a sharp cable cutter with curved beaks to ensure the diameter is not deformed (see figure 3.1). The cable must have no spacing deformation or burrs. The cable must not be stripped. For easy insertion make sure the inserted part of the cable is straight. The to-be inserted end must have a clean straight cut or cut with maximum angle of 10°. After cutting the cable, the cable needs to be assembled with the SOLARKLOK connector immediately!

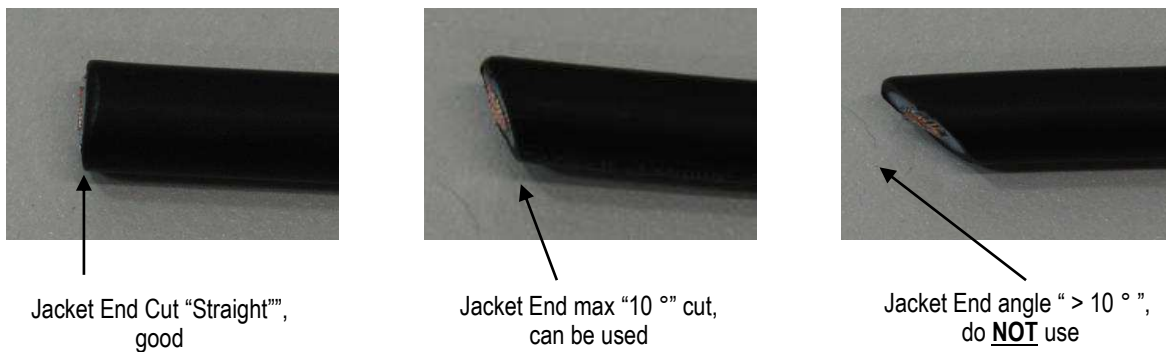

Figure 3.1 Cable cuts



Figure 3.2 TE recommended Knipex cut-tool, 95 05 165 (or equivalent)

3.3. General guidance

Please read 114-137077 for general handling on the PV4-S mating and cable handling.

To ensure correct working of the Solarlok 2.0 it is important to gently route the cable and ensure the bending radius is equal or large then 5 times the cable diameter (see figure 3.3).

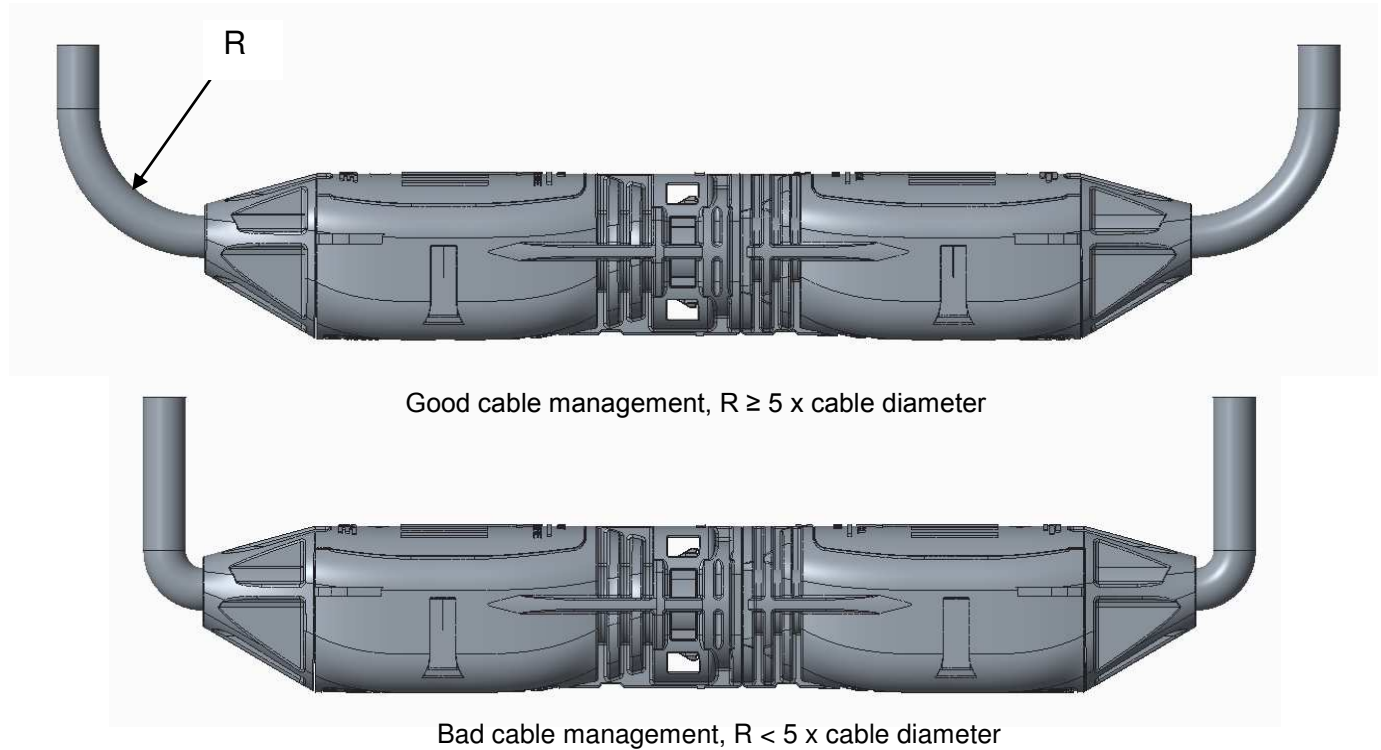

Figure 3.3 - example of cable management

3.4. Cable Insertion

See figure 4.1, a cable must be measured from cable insertion hole up to the indication line (see red line picture below) on top of the SOLARLOK 2.0 button (total cable insertion length is 53.8 ± 2 mm). Best way is to put the finger against the cable insertion hole and let the end of the cable hit the “insert to here” indication line.

Without moving your fingers push Cable in the SOLARLOK 2.0 firmly until your fingers are hitting the cable insertion hole again. If Cable insertion is not going smoothly (false stop, finger not at cable insertion hole), slightly rotate the Cable in both direction will overcome this.

See figure 4.1 for determine the cable insertion length ($53.8\text{mm} \pm 2$ mm) for SOLARLOK connector using TE delatch-tool PN 2342988-1.

See figure 4.1 to determine if the cable is within the min. (5.5mm) and max. (7.2mm) cable-outer-diameter for SOLARLOK connector by using TE delatch-tool PN 2342988-1 (figure 7.1). If the cable-outer-diameter is outside the min or max., do NOT use the cable. Please look in specification 108-133104 for approved and recommended cables.

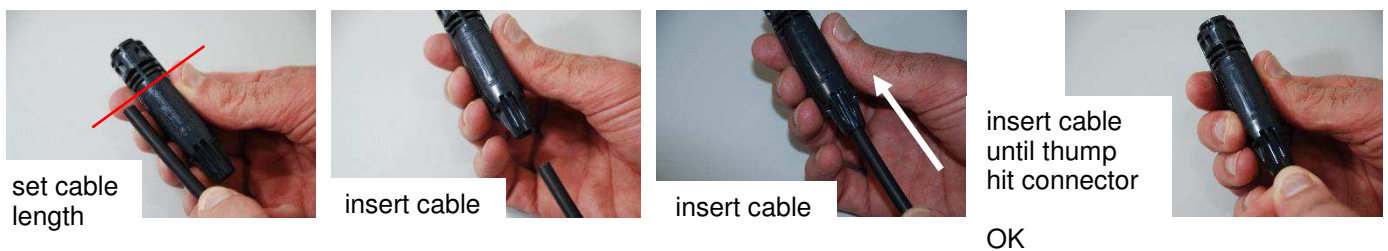

Figure 4.1 - set cable insertion length and insert cable using indicator on connector

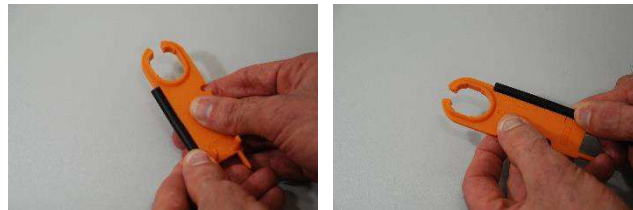

Figure 4.2 – set cable insertion length with delatch-tool PN 2342988-1 (see figure 7.1). Use length indicator on the side of the tool to set the correct cable insertion length ($53.8\text{mm} \pm 2$ mm) for SOLARLOK connector.



Figure 4.3 – determine if cable-outer-diameter is within min. and max. range with delatch-tool PN 2342988-1. Use the min. and max. cable openings on the tool to check if your cable is within the range yes or no.



Note: once the cable is inserted minimum of 25 mm, the cable cannot be retracted due to the cable locking feature (cable is then not yet fully inserted).

3.5. Termination

TE recommends the usage of a Knipex tool 86 03 300 or TE Connectivity handtool PN 2341979-1.



Figure 5.1 - Knipex tool 86 03 300

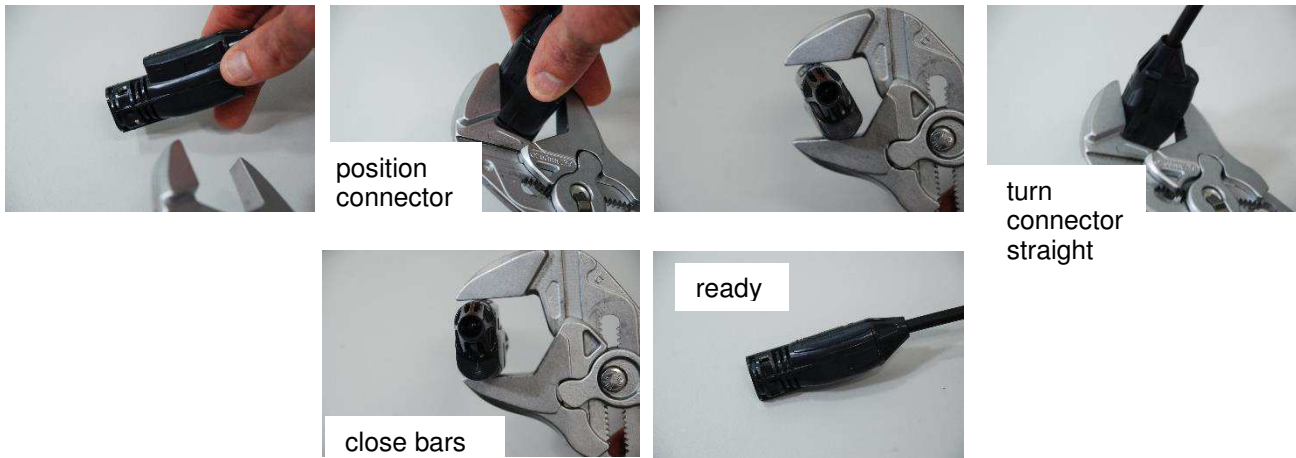

Figure 5.2 - Termination steps with Knipex tool 86 03 300

Set the beak of the pliers to when closed below 26 mm to ensure full closure of the connector.

The anvil of the tool must be placed in the middle of the button to prevent uneven seating.

In case the SOLARLOK 2.0 does not fit in the beak when fully open, you can insert the connector under an angle and rotate to the upright position (ensure the beaks are placed in the middle of the button) or push the button a little by hand (figure 5.2 picture 2, 3 and 4).

The SOLARLOK 2.0 must be slowly and in one smooth movement closed using a maximum force of 500 N [112 lb-force], hold for 1 - 2 seconds (figure 5.2, picture 5). Do not stop half way when pressing down the button and / or try to pull out the button once inserted.

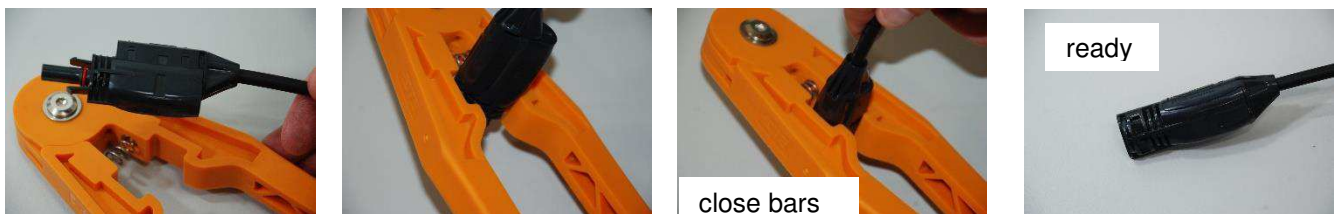

Figure 5.3 - Termination steps with TE handtool PN 2341979-1 (see figure 7.2)

Insert the SOLARLOK 2.0 connector into the flat openings of the TE Connectivity handtool PN 2341979-1 (figure 7.2) and close slowly and in one smooth movement using a maximum force of 500 N [112 lb-force], hold for 1 - 2 seconds (figure 5.3, picture 3). Do not stop half way when pressing down the button and / or try to pull out the button once inserted.



Figure 5.4 – Control termination with TE delatch-tool PN 2342988-1 (figure 7.1)

Use the “Go-No Go” option of the delatch-tool PN 2342988-1. Move the oval shape section of the delatch-tool over the SOLARLOK connector top and move towards the cable. When the SOLARLOK connector is properly terminated, the delatch-tool will smoothly slide over the button. When incorrect terminated, the delatch-tool will NOT slide over the button, and connector is not approved for usage.

Before usage of terminated connector, check the following steps:

A. Cable Placement

The Cable must be firmly inserted till positive stop is felt, see §3.4.

B. Housing

There must be no apparent damage or cracks in the housing.

C. Buttons

The top of the button must be flush with the top of the housing. There must be no apparent damage or cracks in the buttons or housing. The lines on the sides need to be aligned. See figure 6 **Error! Reference source not found.** **Error! Reference source not found.** **Error! Reference source not found.**

D. Connector Height

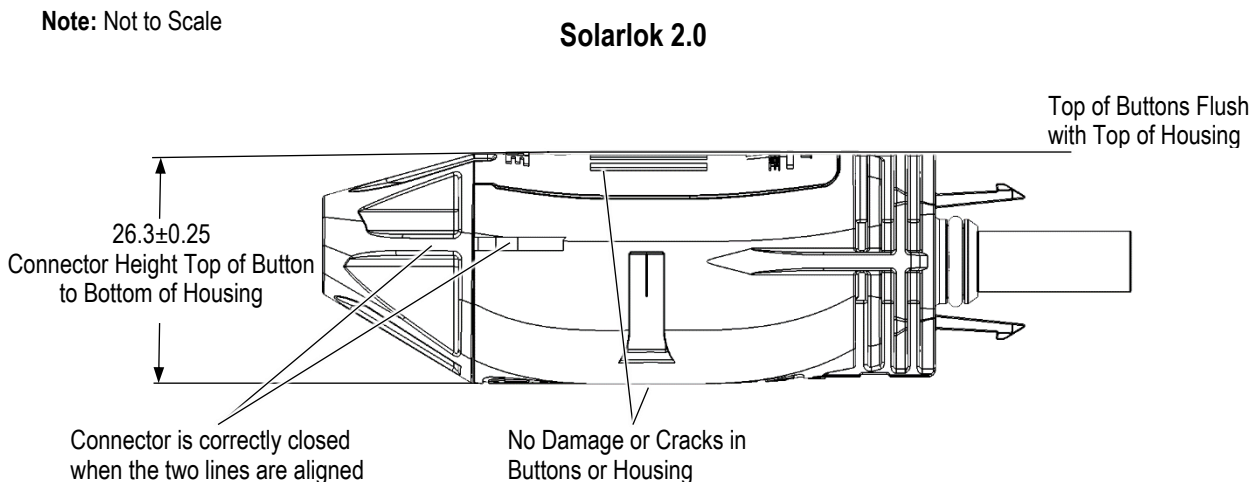

Figure 6 – overview of closed Solarlok 2.0

The connector must be within the connector height dimension given in figure 6.

3.6. Replacement and Repair

A damaged or defective connector must not be used. The connector cannot be repaired. The connector must not be re-used by removing or lifting the buttons before or after termination.

Cut off the connector and replace it with a new one.

4. QUALIFICATION

The 2315176-1 SOLARLOK 2.0 is Listed by Underwriters Laboratories Inc. (UL 6703), file E353372.

The 2315176-1 SOLARLOK 2.0 is certified against IEC 62852, certificate number pending.

The 2308033-1 SOLARLOK 2.0 is Listed by Underwriters Laboratories Inc. (UL 6703), file E353372.

The 2308033-1 SOLARLOK 2.0 is certified against IEC 62852, certificate number pending.

The 2336077-1 SOLARLOK 2.0 Splice is Listed by Underwriters Laboratories Inc. (UL 6703), file pending.

The 2336077-1 SOLARLOK 2.0 Splice is certified against IEC 62852, certificate number pending.

5. TOOLING

Standard slip pliers can be used. General purpose slip pliers with a minimum stroke of 10 mm will do.

TE Connectivity recommends the use of

- Knipex 86 03 300 Slip-pliers-tool, which has smooth vertical moving beaks (figure 5.1)
- Knipex 95 05 165 Cut-tool, for cutting the cable (figure 3.2)
- TE Connectivity handtool PN 2341979-1 (figure 7.2)
- TE Connectivity delatch-tool PN 2342988-1 (figure 7.1)



Figure 7.1 – TE Connectivity delatch-tool PN 2342988-1



Figure 7.2 – TE Connectivity handtool PN 2341979-1

6. MATING AND UNMATING

See below the process steps for connecting (mating) and delatch (unmating) process for the SOLARLOK 2.0 connector with the TE Connectivity delatch-tool PN 2342988-1

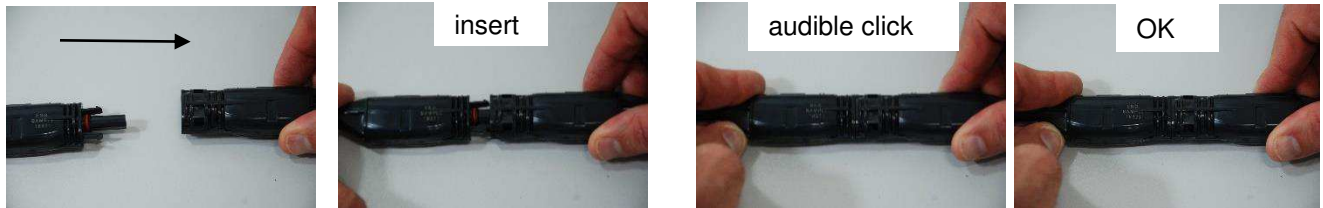

Figure 8.1 SOLARLOK2.0 connector connecting / mating

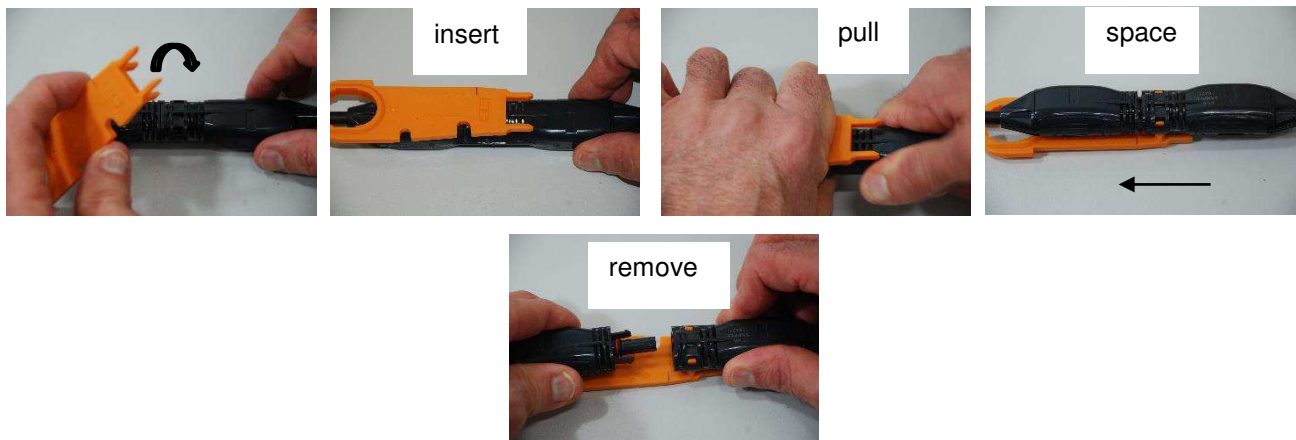

Figure 8.2 SOLARLOK 2.0 connector delatching / unmating